

Operating manual

MAK 10 sample gas conditioner

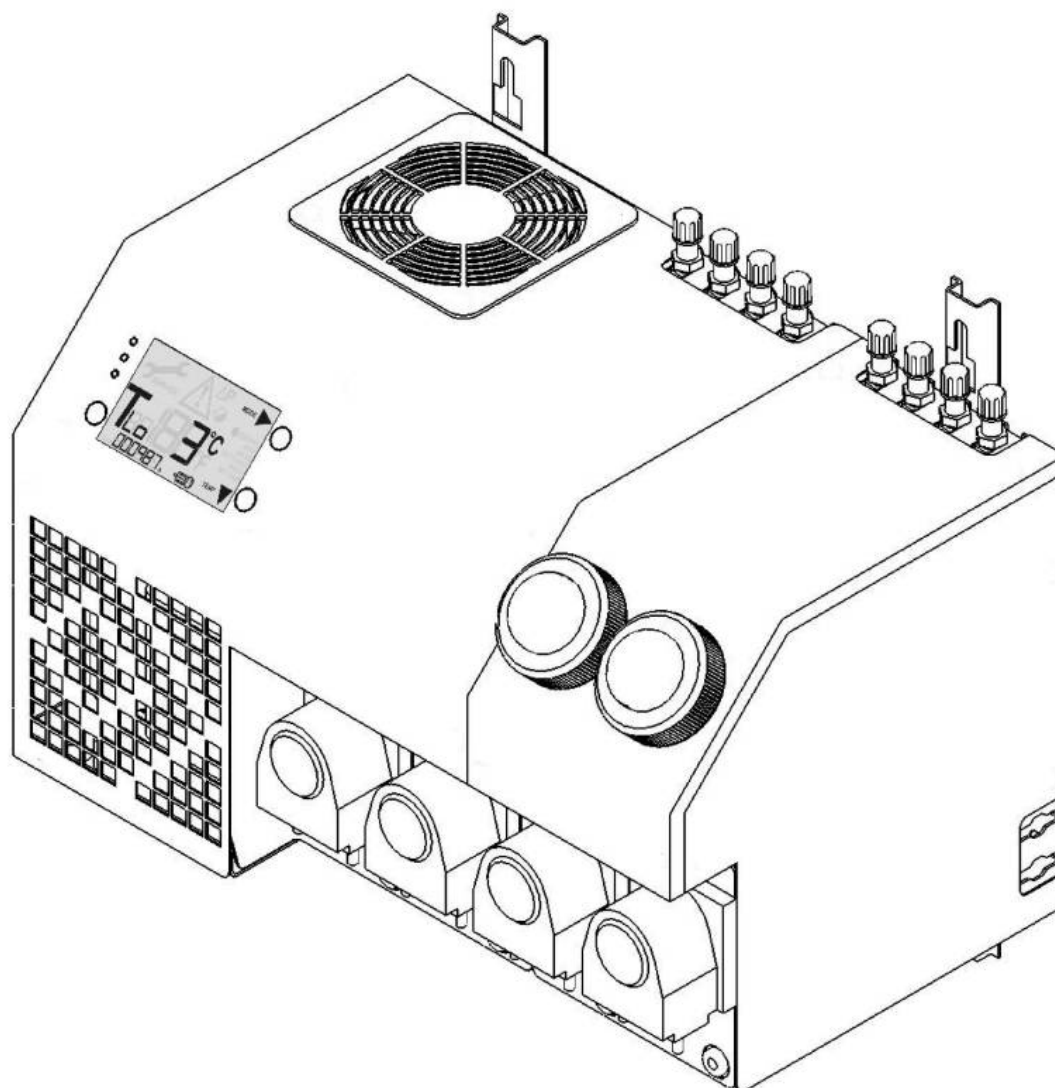

Manufacturer:

AGT Thermotechnik GmbH
Richard-Lucas Street 6
D-41812 Erkelenz

Tel.: +49(0)24 31 96 27 -0
Fax +49(0)24 31 96 27 -31
E-mail: info@agt-thermotechnik.de

0 Contents

0	Contents	2
1	Safety instructions	3
2	Technical specifications	6
3	Description	7
3.1	View of MAK	7
3.2	Control keypad with status displays	8
4	Intended application and tasks of MAK	11
4.1	Cooling the sample gas	12
4.2	Condensate and condensate discharge	14
4.3	Optional components	14
4.4	Service	15
5	Electrical connection	16
5.1	Mains supply	16
5.2	Circuit diagram of the electronic control unit	16
6	Installation instructions	17
7	Commissioning	17
7.1	Supply connections	18
8	Decommissioning	18
9	Alarm statuses and their redressal	19
9.1	Service alarm	19
9.2	TLO alarm	19
9.3	TA alarm	19
10	Spare parts lists	20
11	Guarantee conditions	20
12	Appendix	21

1 Safety instructions

Dear Customer,

Thank you for choosing MAK sample gas conditioner. You have selected a device that facilitates long-term and error-free use when installed and operated as directed.

Please read this installation and operating manual carefully before installing and commissioning MAK sample gas conditioner and follow our instructions!

Only if the described guidelines and instructions are followed accurately is the smooth functioning of MAK and therefore consistent sample gas conditioning ensured.

The manufacturer does not bear any responsibility if the guidelines regarding safety devices and instructions given in this operating manual are not followed. This also applies to operation, service and repair even if the same has not been referred to explicitly in this operating manual.

Installation and commissioning must be carried out only by appropriately trained and qualified personnel as per the normal methods. The resulting general rules for proper installation and commissioning may not be included in this manual entirely.

No liability is assumed for regulations and instructions that do not pertain to the device. If statements in this manual conflict with statutory or other prevailing regulations, they must be replaced accordingly. This does not affect other statements.

Accident prevention guidelines as prescribed by the statutory professional associations must be followed.

Tampering the safety and security devices is not permissible. During the guarantee period, the cooling circuit should be handled only by the qualified personnel of the manufacturer or thereafter, only by an expert in conformity with DIN EN 378.

MAK should not be operated in explosion-prone areas.

Corresponding guidelines must be adhered to while operating MAK with toxic and explosive gases.

Transportation and storage

CAUTION: MAK should be transported only in the ready-to-install condition.

MAK can only be exposed to temperatures between -20°C and $+65^{\circ}\text{C}$ while transporting and storing. The maximum air humidity should not exceed 80%.

On its arrival, the delivery must be checked for completeness and possible damages with the help of the dispatch documents. In case of damages in transit or loss, the haulage company must prepare a damage report for asserting the claims for compensation as regards insurance. Damages can be asserted only if appropriate documentation (e.g. photos) for the same is available. If damages, which may result in further damages, occur, then the customer is obligated to enforce the greatest possible damage limitation. No liability is assumed for avoidable and consequential damages.

If damages are identified only after commissioning for the first time, then the operator is obliged to take all possible measures to avoid consequential damages. Initial measures in this context would be, e.g. unplugging the mains plug.

Setup and installation

Main dimensions are given in the measurement drawings of MAK. The weight is specified on the rating plate.

CAUTION: Free space required for ventilating and bleeding the MGA at the front and top opening must be maintained for smooth functioning. It should not be less than 40 mm.

The ambient temperature should not fall below $+5^{\circ}\text{C}$ or exceed $+45^{\circ}\text{C}$ at the installation site that has been protected against cold weather.

If the dew point in the sample gas pipeline between the outlet probe and the MAK inlet falls, the sample gas pipeline must be equipped with a steam trace to avoid condensate waste.

Electrical connection

MAK sample gas conditioner must be installed as shown in the electrical circuit diagram, illustration 5. The cross-section of access lines and the local fuse rating must conform to the maximum power consumption as mentioned on the rating plate. Power is supplied via cable and the mains plug. The feed length should not exceed 3 m for the given fuse rating.

Requirements of VDE 0100 as well their relevant standards and guidelines must be adhered to while setting up high-voltage devices with rated voltages of up to 1000 V.

Caution:

The mains plug must be pulled out to isolate it completely from the mains. MAK must be plugged in without voltage before switching it on so as to protect it from coming in contact with undue high voltages. This is also applicable for connected external circuits, if any.

The customer should follow the local fuse rating of devices. Technical specifications are to be inferred from the rating plate and the technical data sheet given in this manual. If MAK is connected to the mains voltage and switched on, either the green lamp for operation, the yellow lamp for service or the red lamp for interruption lights up. If the device is switched off, no lamp lights up.

Please contact AGT Thermotechnik if MAK fails. When properly used, we provide a guarantee of 1 year starting from the delivery date as per the general sales and delivery conditions of AGT. This excludes wearing parts. The guarantee service covers free repairs in the company or free replacement of the device that has been sent to the place of application free of charge. Return deliveries must take place in suitable and sound protective packing.

2 Technical specifications

Model	Modell	MAK 10-1101	MAK 10-2202	MAK 10-4404	MAK 10-1112	MAK 10-2224
Number of gas paths	Anzahl der Gaswege	1	2	4	1	2
Pre-separator (PS)	Vorabscheider (PS)	-	-	-	1	2
Operation data	Betriebsdaten					
Gas flow per gas path	Gasvolumen pro Gasweg	125 NI/h	125 NI/h	100 NI/h	150 NI/h	150 NI/h
- dew-point at inlet	- Taupunkt am Eintritt	65°C				
Gas flow per gas path	Gasvolumen pro Gasweg	175 NI/h	175 NI/h	140 NI/h	200 NI/h	200 NI/h
- dew-point at inlet	- Taupunkt am Eintritt	55°C				
Gas temperature at inlet	Gastemperatur am Eintritt	140°C				
- maximum	- maximal	140°C				
Ambient temperature	Umgebungstemperatur	5 - 45°C				
Operating pressure (abs.)	Betriebsdruck (abs.)	0.5 – 2.2 bar				
Gas dew-point at outlet	Gastaupunkt am Austritt	3°C +/- 0.3				
Press. drop per gas path	Druckverlust pro Gasweg	5 mbar (V = 125 NI/h)				
Dead space per gas path	Totvolumen pro Gasweg	26 ml				
Ready for start-up	Betriebsbereitschaft	< 5 min.	< 10 min.	< 15 min.	< 5 min.	< 10 min.
Cool. capacity ta = 45°C	Kühlleistung tu = 45°C	220 W		300 W	220 W	
Material of gas paths	Material der Gaswege					
Cooling transfer tube	Kälteübertragungsrohr	Aluminium				
Cooling surface	Kühlfläche	PTFE -Coating / -Beschichtung				
Housing / Sealings	Gehäuse / Dichtungen	PVDF / Viton				
Design data	Konstruktionsdaten					
Width	Breite	310 mm		449 mm	310 mm	449 mm
Height	Höhe	266 mm		266 mm	266 mm	266 mm
Depth	Tiefe	271 mm		271 mm	271 mm	271 mm
Weight	Gewicht	16 Kg	17 Kg	20 Kg	17 kg	20 Kg
Housing	Gehäuse	Wall-mount / Wandmontage				
Housing 19"	19" Gehäuse	Option				
Colour	Farbe	RAL 7032				
Gas connection	Gasanschluss	PVDF DN 4/6				
Condensate connection	Kondensatanschluss	PVDF DN 4/6				
Electrical data	Elektrische Daten					
Mains connection	Netzanschluss	Plug / Netzstecker				
Alarm: cable open-end	Alarm: Anschlusskabel	250 V, 2 A, 50 VA				
Alarm set points	Alarmgrenzwerte	< + 2°C / > + 10°C				
Housing protection class	Gehäuseschutzart	IP 20 EN 60529 / EN 61010				
Power supply	Stromversorgung	230 V, 50 Hz; -15% / +15%				
Power consumption max.	Leistungsaufnahme max.	152 W		214 W	152 W	
Power supply	Stromversorgung	230 V, 60 Hz; -10% / + 10%				
Power consumption	Leistungsaufnahme	182 W		256 W	182 W	
Power supply	Stromversorgung	115 V, 50/60 Hz; -10% / + 10%				
Power consumption	Leistungsaufnahme	190 W		265 W	190 W	

3 Description

3.1 View of MAK

Illustration 1: View of MAK

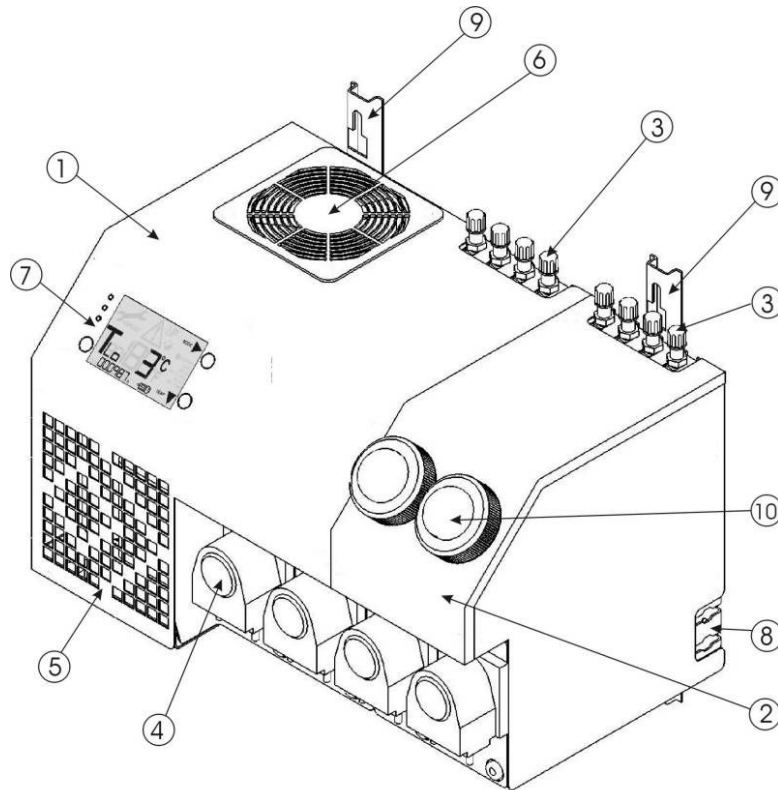

- 1 Housing for MAK10-1101; MAK10-1112 and MAK10-2202
- 2 Housing attachment for MAK10-2224; MAK10-3303 and MAK10-4404
- 3 Gas inlets and outlets as well as the number of gas inlets and outlets depend on the device type
- 4 Condensate pumps and the number of condensate pumps depend on the device type
- 5 Cooling air inlet
- 6 Cooling air outlet
- 7 Control keypad with status displays
- 8 Current and flow signal cable output
- 9 Attachment rails of MAK
- 10 Teflon depth filter (TF) (optional)
- 11 Moisture guard (MS) not shown (optional)

3.2 Control keypad with status displays

Illustration 2: Control keypad with status displays

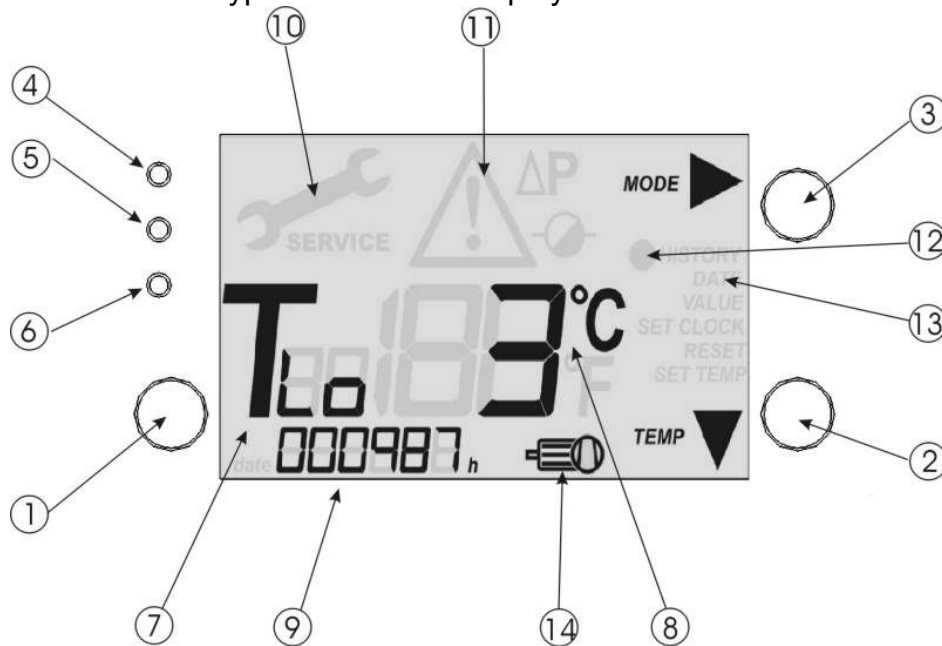

1 On / Off switch

The On/Off switch is used to switch MAK on or off

2 Temperature selector switch

The temperature selector switch is used to alternate between the gas cooling temperature T_{LO} and the cooling air temperature T_A

3 Switch for displaying / changing operating modes

Displaying the operating modes using button 3

Press once = display of the operating hours during which an interruption occurred. Last 5 interruptions can be displayed when button 2 is pressed one or more times.

Press twice = display of temperatures of the previously set interruption. Different temperatures of interruptions can be displayed when button 2 is pressed one or more times.

Press thrice = mode for displaying the switch-on time of the condensate pumps.

Press four times = mode for displaying the switch-off time of the condensate pumps.

The device shows default values if a keypad input is not given within 10 s.

Changing the operating modes using button 3

Press button 3 once for 2 seconds = mode for changing the switch-on time of the condensate pumps. The switch-on time of the condensate pump can be changed when button 2 is pressed one or more times. Setting range 2 – 10 min.

Press button 3 once for 2 seconds and then press it once = mode for changing the switch-off time of the condensate pumps. The switch-off time of the condensate pump can be changed when button 2 is pressed one or more times. Setting range 0 – 10 min.

Press button 3 once for 2 seconds and then press it twice = mode for changing from °C to °F. When button 2 is pressed once, the temperature display changes from °C to °F or vice versa.

Press button 3 once for 2 seconds and then press it thrice = mode for changing the switch-on and switch-off time of the condensate pumps to default settings. Condensate pumps are reset to default settings, i.e. 5 min on and 0 min off, by activating the mode for changing the switch-on and switch-off time of the condensate pumps.

Without keypad input, the setting is saved after 10 s in all operating modes.

- 4 Green LED = MAK switched on
MAK is switched off when no LED lights up. MAK is switched on when the green LED lights up.
- 5 Yellow LED = service required
The device must be serviced when the yellow and green LED light up. Also refer to point 4.4 Service.
- 6 Red LED = alarm
When the red, yellow and the green LED light up, it indicates that the service interval has exceeded twice the scheduled service period. The floating output is switched on. Also refer to point 4.4 Service.

Temperatures exceeding the measured values have been recorded by MAK if the red and green LED light up. The floating output is switched on.

If the exceeded temperature is compensated, the alarm is switched off and a point appears in display 12, which indicates that an erroneous value has been saved.

Illustration 3: Control keypad with status displays

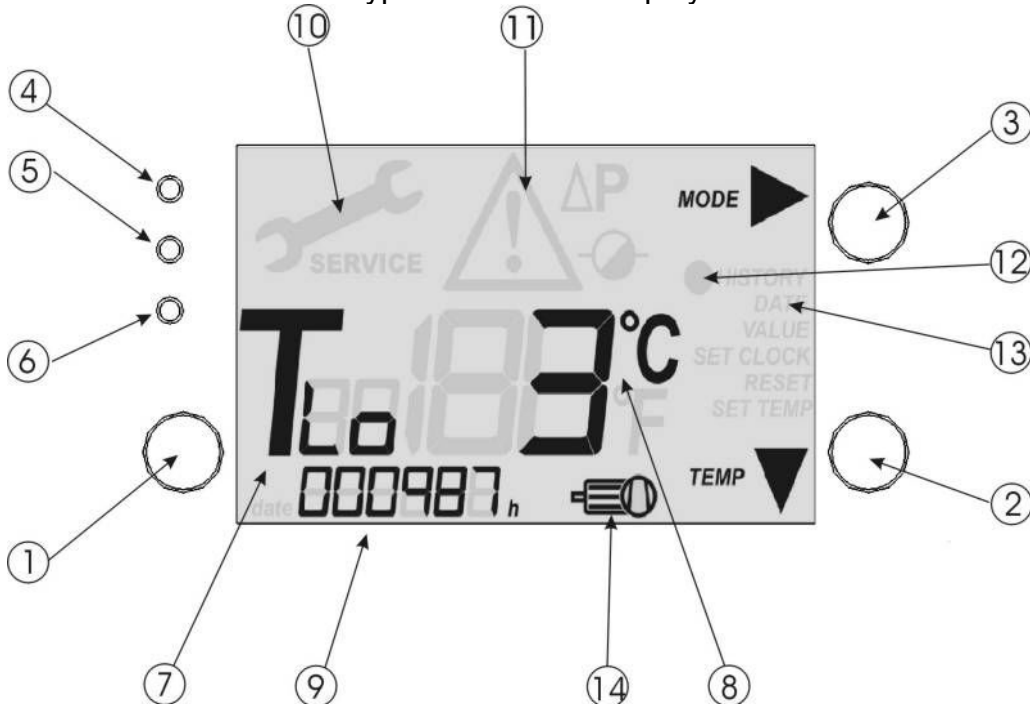

- 7 and 8 Temperature displays
 Gas cooling temperature = T_{Lo} ;
 Cooling air temperature = T_A
 As a rule, T_C , T_4 and T_5 are not reserved
- 9 Display of the operating hours
 Operating hours of MAK are always displayed and they can be cleared by pressing buttons 2 and 3 simultaneously. Counting starts from 0 after reaching 65,000 operating hours.
- 10 Service required
 MAK must be serviced. Also refer to points 5 and 6.
- 11 Alarm
 Service or temperature alarm has been activated. Refer to point 6 for description.
- 12 Alarm value saved
 The alarm value has been saved. Refer to point 3 for description.
- 13 Current operating mode
 In the modification mode, this display shows the currently set operating mode. Refer to point 3 for description.
- 14 Condensate pump(s) switched on
 This display shows that condensate pump(s) are switched on. Refer to point 3 for description of switch-on / switch-off time.

4 Intended application and tasks of MAK

MAK is used in the sequence of sample gas conditioning, wherein cross-sensitivity may not be observed in case of infrared analysers due to low and constant dew points. At no subsequent point does the dew point decrease. The analyser is protected from the moist sample gas.

Tasks of the basic version of MAK are

- ⇒ Cooling the sample gas
- ⇒ Separating the condensate and
- ⇒ Discharging the condensate

MAK can, if required, optionally execute other tasks for sample gas conditioning

- ⇒ Pre-cooling the sample gas with condensate pre-separation and condensate drain
- ⇒ Gas cleaning
- ⇒ Moisture guard

4.1 Cooling the sample gas

Principle:

MAK has 1.....4 heat exchangers I-IV, wherein the sample gas is cooled to approximately 3°C.

Refrigerant circuit:

Depending on the operating conditions, the refrigerant compressor 1 compresses the vaporous refrigerant from the inlet pressure of approximately 210 kPa (= 2.1 bar) to the condensation pressure of 800-1700 kPa (= 8-17 bar).

The vaporous refrigerant is liquefied by cooling in the subsequent air-cooled refrigerant condenser 2. The fluid refrigerant is passed through the refrigerant drier 3 to the capillary tube 4.

The fluid refrigerant is expanded in capillary tube 4 from the condensation pressure 800-1700 kPa (= 8-17 bar) to the evaporation pressure 210 kPa (= 2.1 bar) and then fed to evaporator 6 of heat exchanger 5.

Energy is extracted from the sample gas in heat exchanger 5; the sample gas is cooled and the energy is supplied to evaporator 6. This vaporises the fluid refrigerant at an evaporation pressure of 210 kPa (= 2.1 bar, approximately +3°C). The vaporous refrigerant is again sucked by refrigerant condenser 1 via steam dome 10.

Superheated steam bypass valve 9 controls the volumetric flow of refrigerant of evaporator 6 depending on the capacity requirement so that the outlet temperature of the sample gas (dew point) is maintained constant. The evaporation is maintained constant due to the bypass. Since temperature and pressure of the refrigerant are directly correlated, bypass controller 9 ensures a constant dew point temperature of the sample gas in the entire performance range.

Illustration 4: MAK flow chart

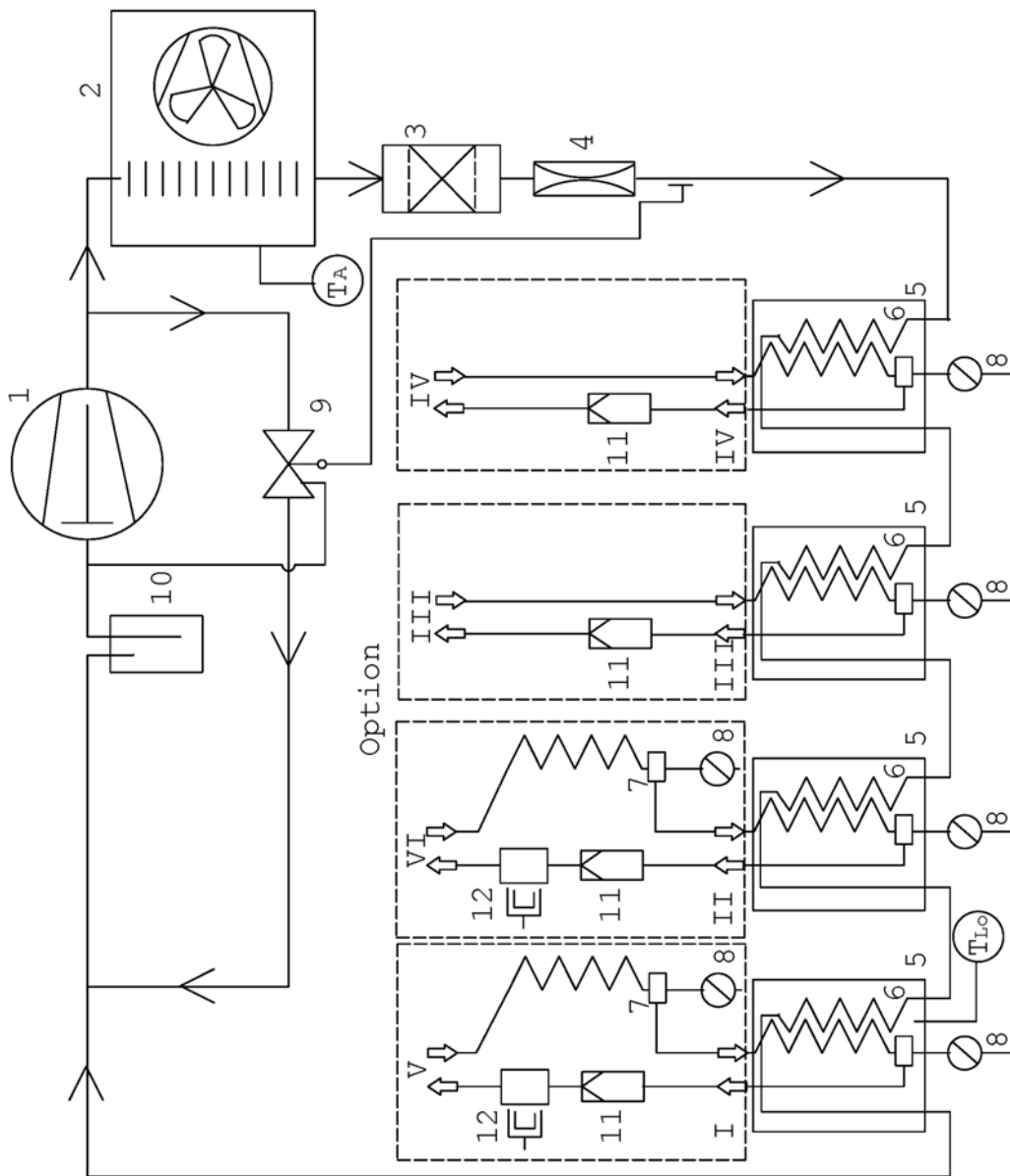

- 1 Refrigerant compressor
- 2 Refrigerant condenser
- 3 Refrigerant drier
- 4 Capillary tube
- 5 Heat exchanger unit
- 6 Evaporator
- 7 Condensate separator
- 8 Condensate pump
- 9 Superheated steam bypass valve
- 10 Steam dome
- 11 Teflon – depth filter
- 12 Moisture guard
- T_{Lo} dew point temperature
- T_A cooling air temperature
- I – IV cooler gas path 1 – 4
- V – VI pre cooler, pre-separator

4.2 Condensate and condensate discharge

The sample gas is cooled to approximately +3C° in heat exchanger 5. Water vapour condenses along the dew point line as a result of the cooling. Condensate is separated from the sample gas and collected in the condensate separator of heat exchanger 7. Condensate is continuously discharged at the rate of 3.4 ml / min for every gas path using the connected condensate pump 8 or with the help of time-interval control.

4.3 Optional components

Condensate pre-separator

Condensate pre-separators V and VI can be used for measuring points at high inlet temperatures of up to 180°C and high inlet dew points greater than 65°C. The capacity of heat exchangers I and II is thus affected favourably. The sample gas is pre-cooled in condensate pre-separators V and VI by the ambient air. On reaching the dew point, water vapour condenses along the dew point line as a result of the cooling. Condensate is separated from the sample gas and collected in the condensate separator of pre-separator 7.

Condensate is continuously discharged at the rate of 3.4 ml / min for every gas path using the connected condensate pump 8 or with the help of time-interval control.

Teflon – depth filter

Particles of up to 0.1 y are reliably filtered by Teflon depth filter 11.

Moisture guard

Moisture guard 12 monitors the functioning of the cooling system and the condensate pumps. An individual error message is displayed in case of an alarm. If the gas pump is integrated into the safety chain, it is switched off in case of an alarm. The analyser is protected against condensate breakdown.

4.4 Service

- ⇒ A service signal (illustration 2) “without alarm” is initiated after 4,500 hours. A service alarm with an error message is initiated after the next 4,500 hours if no actions, like e.g. servicing, are taken. It is recommended to reset the display of the operating hours of the electronic unit to 0 hours. Buttons 2 and 4 (illustration 2) must be pressed for 2 seconds simultaneously to reset the display of the operating hours
- ⇒ Changing the pump hose:
When the condensate pump is operated for a long time, the pump hose eventually wears out. Condensate may leak from the pump hose. In this case, the pump hose must be replaced immediately as there is a risk of external air being sucked from porous points, which may lead to false readings. We recommend replacement of the pump hose after every 3 months as a precautionary measure. Follow the simple guidelines for handling the condensate before and while changing the condensate tube. MAK must be switched off before changing the condensate tubes. Connectors of the pump hose, the condensate connections of MAK and the condensate line must then be separated; **“Caution! Condensate may leak”**. The lock of the pump hose must then be rotated clockwise till the bearing surface can be dismantled. After dismantling the bearing surface, the pump hose can be disconnected from it along with the connectors. The new pump hose must then be mounted onto the bearing surface. The bearing surface of the condensate pump must then be fit on the pump. The lock of the pump must be rotated anti-clockwise in order to fix the bearing surface. After bolting the bearing surface, connectors of the pump hose and condensate connections of MAK and the condensate line must be re-connected.
- ⇒ Refrigerant condenser: The capacity of a sample gas cooler is influenced by the contamination degree of the condenser. MAK must be switched off (MAK should not carry current). The housing must be opened. Air-cooled condensers must be cleaned using a soft brush or compressed air. **“CAUTION: Protective goggles must be worn while cleaning the condenser using compressed air (do not blow too strongly)”**. Servicing must be done at regular intervals depending on the degree of contamination.
- ⇒ Changing the sample gas filter (optional):
Cartridge of the depth filter must be replaced in case of contamination. The sample gas pump must be switched off before changing it. The clamping nut of the filter casing can then be removed. **“Caution! The filter glass may fall out of the clamping nut”**. After unscrewing the clamping nut, the filter cartridge can be replaced by taking it out and inserting a new one in. The clamping nut must now be fixed along with the filter glass.

5 Electrical connection

5.1 Mains supply

The mains supply is established via a Schuko connector for 230 V MAK devices or via a connector as per the US-model for 115 V MAK devices. Correct voltage type as mentioned on the rating plate must be taken into account while establishing connections.

5.2 Circuit diagram of the electronic control unit

Illustration 5: Circuit diagram of the electronic control unit:

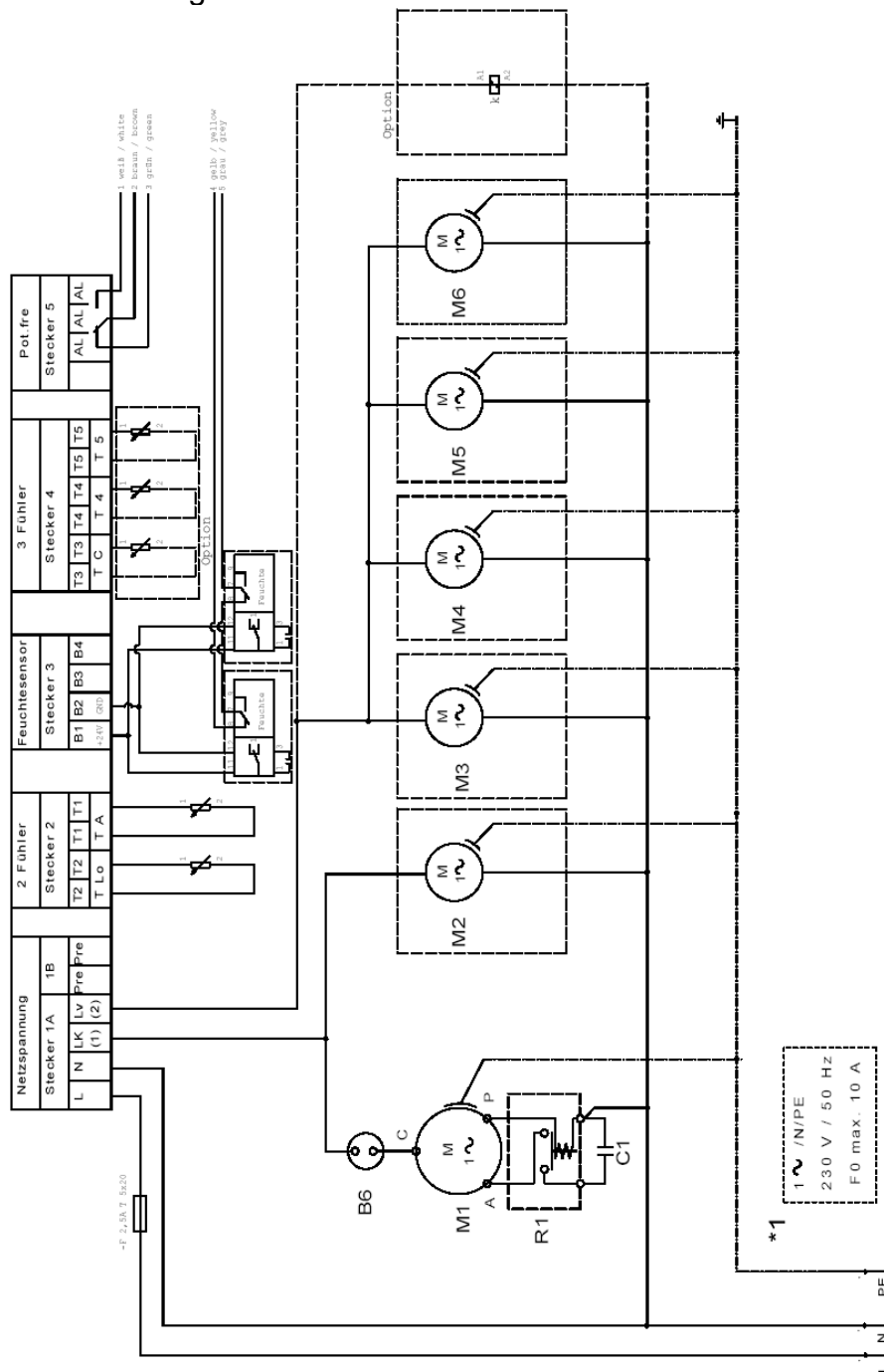

6 Installation instructions

The layout of the compact MAK sample gas conditioner guarantees problem-free integration into the analysis systems.

Ensure unhindered air circulation while installing MAK. Do not install directly above possible sources of heat. Connect heated discharge lines to a cooling unit using suitable thermal decoupling!

Install MAK in a protective casing when used for outdoor applications, with a frost-free unit when used in winter and with adequate ventilation when used in summer. Avoid direct solar radiation.

Lay the condensate drainage line outside MAK with an adequately dimensioned gradient and without counter pressure. **“CAUTION: Do not drain the condensate into the sewage system without treating it first!”** Sample gas condensate is a special waste that should not be drained in the public sewage system or in water bodies. Guidelines as regards the condensate disposal as per the Water Resources Act (WHG) must be adhered to.

7 Commissioning

System and process-specific safety measures must be followed before commissioning!

Requirements of VDE 0100 as well their relevant standards and guidelines must be followed while setting up high-voltage devices with rated voltages of up to 1000 V! The power supply circuit of the device must be equipped with a fuse compatible with the rated current (overcurrent protection). Electrical specifications can be inferred from the technical specifications.

The following steps must be executed before commissioning MAK:

- ⇒ Connect the device to the mains; compare the mains voltage with the specifications given on the rating plate before commissioning;

7.1 Supply connections

As a standard, medium connections of MAK have been designed for a 6/4 hose!

The following feed lines must be connected (illustration 4):

- ⇒ Sample gas pipeline(s) to the gas inlet connections “Gas inlets I - VI”
- ⇒ Analyser(s) to the gas outlet connections “Gas outlets I - VI”
- ⇒ Condensate drain to the condensate pump connections

8 Decommissioning

The following steps must be executed before decommissioning MAK:

- ⇒ Switch the device off using the electronic switch 1.
- ⇒ Disconnect the device from the mains.
- ⇒ Remove the feed lines; **“Caution! Corrosive condensate may leak from the condensate pump connections”**. Please follow the simple guidelines mentioned while handling the condensate.
- ⇒ If the device has come in contact with toxic gases, the corresponding guidelines must be followed.
- ⇒ Sample gas conditioning must be disposed off in a specialised manner. Please contact your manufacturer or an adequately qualified person for the disposal of MAK.

9 Alarm statuses and their redressal

9.1 Service alarm

Service alarm is initiated if servicing has not been carried out even after 9000 operating hours. The floating output is switched on.

It is recommended to follow points 3.2.5 and 3.2.6.

The initiated service alarm remains activated till it is consciously acknowledged. Switches 2 and 3 (refer to illustration 2) must be pressed for 2 seconds simultaneously to redress alarm statuses. This resets the operating hours display to 0 hours.

9.2 T_{LO} alarm

T_{LO} alarm is initiated when the cooler temperature is $< 0.5^{\circ}\text{C}$ or $> 10^{\circ}\text{C}$. This must be taken into account particularly during the cooling phase of the heat exchanger after commissioning MAK.

The following tests must be conducted for a T_{LO} alarm:

Functional test of the compressor cooler.

If the exceeded temperature is compensated, the alarm is switched off and display 12 (refer to illustration 2) indicates by way of a point that an erroneous value has been saved.

9.3 T_A alarm

T_A alarm is initiated when the cooler temperature is $< 5^{\circ}\text{C}$ or $> 45^{\circ}\text{C}$.

The following tests must be conducted for a T_A alarm:

Check whether an adequate tempering, with an ambient temperature of max. 45°C and min. 5°C , is ensured above and at the front of MAK, with the help of, e.g. other heat radiating devices.

If the exceeded temperature is compensated, the alarm is switched off and display 12 (refer to illustration 2) indicates by way of a point that an erroneous value has been saved.

10 Spare parts lists

Product	AGT product no.
Sight glass for the filter	6400086
Filter cartridge for the front panel built-in filter	6400085
Glass tube for the condensate pre-separator	6404000
Glass tube for the condensate sensor	6404050
Electronic unit	7010010 + 8813033
Front film for the electronic unit	7880637
2-series temperature sensor set	6501090
Alternating heat exchanger as a replacement	8410779 + 3 x 6940580
115 V ventilator	6600365
230 V ventilator	6600364
Hose with a bolted joint for the condensate / conditioning pump	8600002
Turning out safety device 2.5 A slow-acting	6663179

11 Guarantee conditions

Guarantee for MAK sample gas conditioner

The purchase proof forms the basis for all guarantee claims. Damages caused due to improper handling of MAK are not included within the scope of the guarantee.

Damages caused due to non-adherence to this installation and operating manual are not included within the scope of the guarantee.

We request you to specify complete details of the model name given on the rating plate of MAK in case of queries.

Rating plate

The rating plate that is provided on the right of the mounted housing and at the back of the 19" MAK sample gas conditioners contains all important details. Please specify the model number in case of queries and service. Guarantee becomes void even if the rating plate is partially removed.

The following has been excluded from the scope of the guarantee, particularly:

- ⇒ Wearing parts
- ⇒ Damages caused due to overloading MAK
- ⇒ Damages caused due to defective electrical connection
- ⇒ Damages caused due to improper use
- ⇒ Damages caused due to lack of service
- ⇒ Damages caused due to improper installation
- ⇒ Damages caused due to events that are beyond the control of the manufacturer

CAUTION: Only the qualified personnel of the manufacturer are allowed to handle the cooling circuit during the guarantee period.

MAK sample gas conditioner must be in the original condition when guarantee claims are made.

12 Appendix

Dimension sheet for MAK 10-1; 10-2 sample gas conditioner

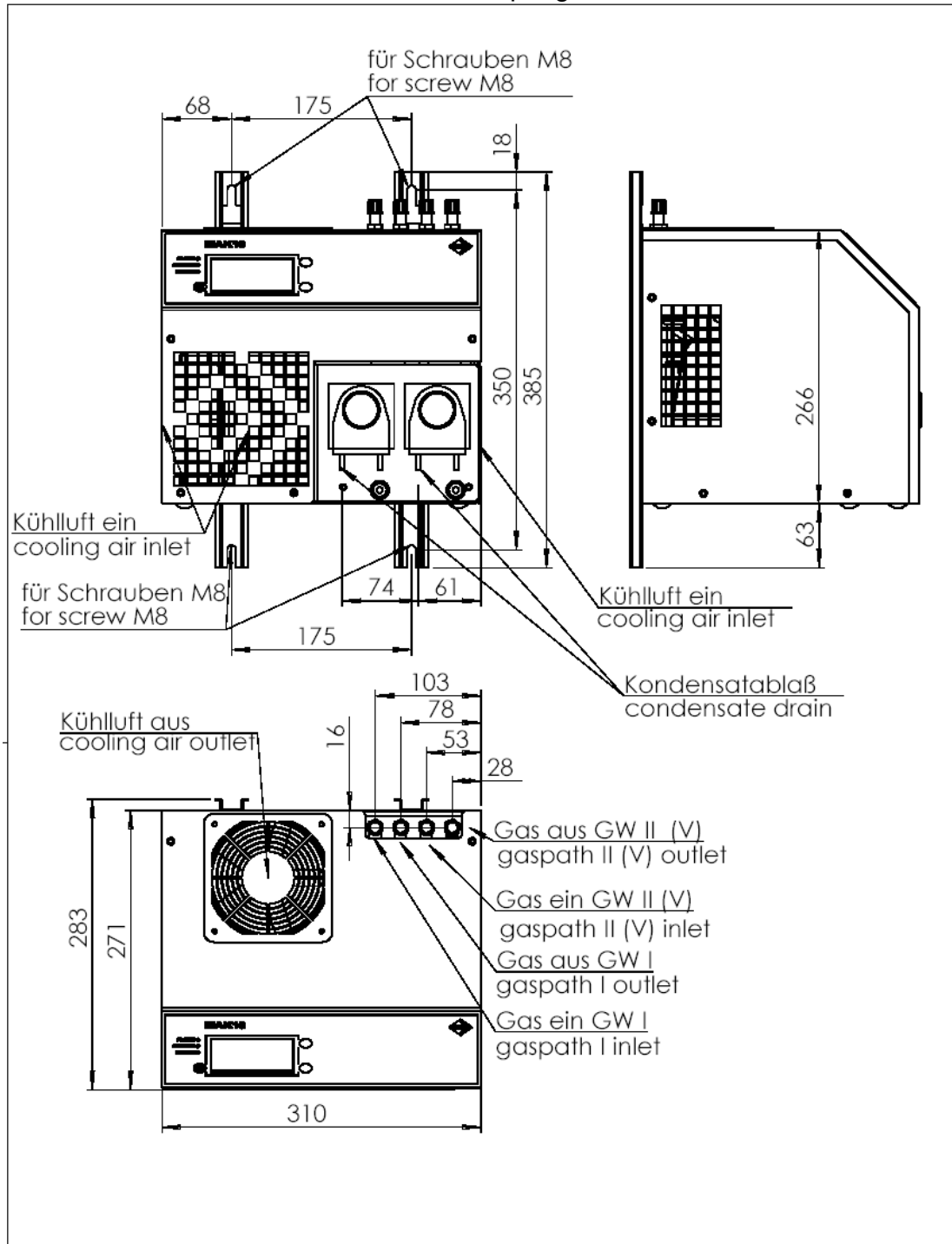

Änderung	Tag	Name	Tag	Name	Maßblatt MAK 10-1; 10-2 dimension sheet
B	23.12.04	bh	05.07.2004	bh	
A	10.08.04	bh	Norm		
Oberflächen nach DIN ISO 1302		Urheber- u. Mißbrauchschutz n. DIN 34 vorh.		A4	8351464
Allgemeintoleranzen DIN ISO 2768m		AGT Thermotechnik		B	
Maßstab: 1:5	V:\solidworks\MAK10\				

Dimension sheet for MAK 10-3; 10-4 sample gas conditioner

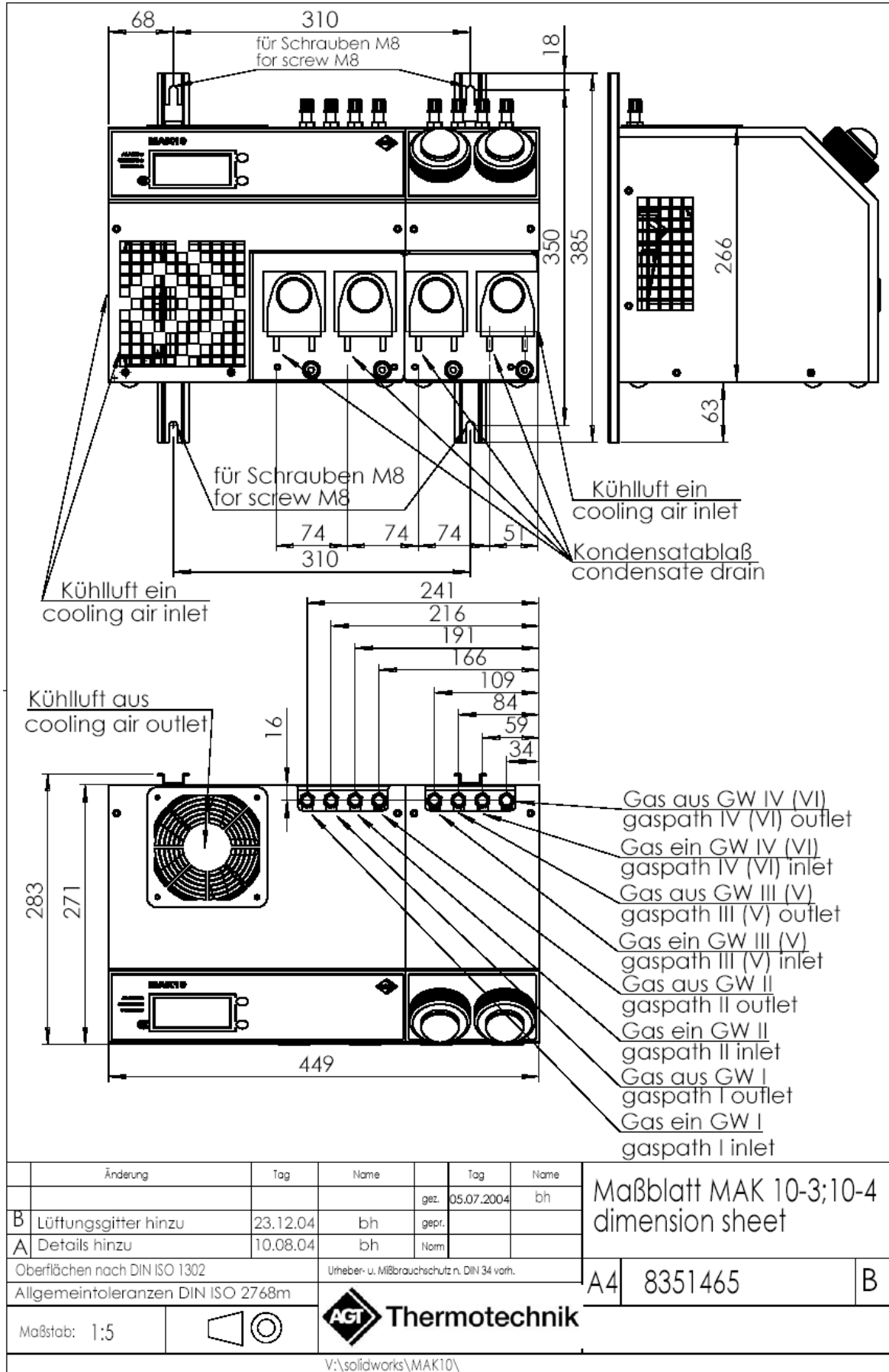

Circuit diagram of the MAK sample gas conditioner

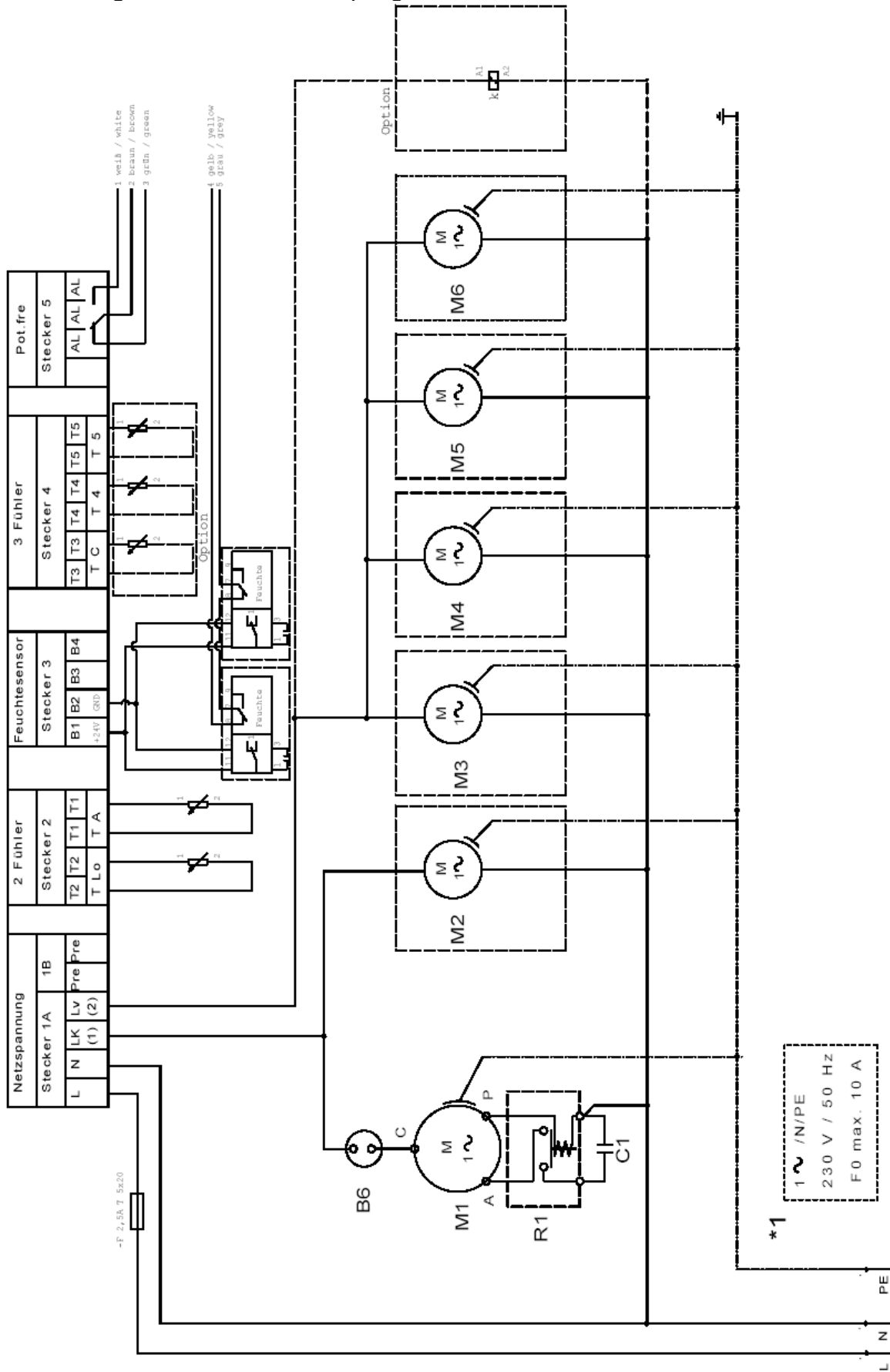

Subject to errors and changes.



AGT Thermotechnik GmbH

Richard-Lucas Street 6 D-41812 Erkelenz

Telephone: +49 (0)2431 9627-0 Fax: +49 (0)2431 9627-31

E-mail: info@agt-thermotechnik.de Website: www.agt-thermotechnik.de