

PSG Plus Cooler

MAK 10

Application

The compact gas conditioning systems series **MAK 10** are used for continuous extractive gas analysis. They serve primarily for exact constant lowering of the sample gas dew point and thus for drying of the humid sample gas flow. In this way water vapor cross sensitivities and volumetric errors are minimized and damages of the sensible analyzer are avoided. With optional components like condensate pumps, pre-separators, filters, liquid sensors, flow meters and sample gas pumps devices of series **MAK 10** can be upgraded to complete compact quick and simple integrable conditioning systems. The flexible modular design guarantees an optimum adaption to every measuring task.

Technology

The precise proportional temperature control in combination with the long-lasting hot-gas bypass system and the innovative corrosion resistant heat exchangers achieves low extremely constant dew points. Also load fluctuations and high thermal stress is compensated reliably. The hydrophobic corrosion resistant PTFE coating and the very short retention time in the heat exchanger ensure a lowest possible gas dissolution rate.

Functions

An electronic system controls dew point and cooling air temperature. Potential free alarm contacts allow remote monitoring of the device. The operating parameters are stored in a log book for diagnosis. An operation hours counter controls the service intervals. Available housing versions are wall mounting housing, 19"-rack housing and mobile versions with carrying handles.



- ✓ Optimized jet stream heat exchanger principle
- ✓ High performance compressor cooler
- ✓ Long lasting hot-gas bypass system without switching the compressor
- ✓ Corrosion resistant PTFE / PVDF heat exchanger
- ✓ Very compact design
- ✓ Digital display for temperature, alarms, logbook, operating hours counter and service interval indication
- ✓ Modular upgradeable and application dependently configurable
- ✓ 1 - 4 gas paths
- ✓ Integrable filters, flow meters, flow alarms, liquid sensors, gas pumps, pre-separators und acid dosing
- ✓ Wall mounting, 19"-rack, or mobile housing

Technical Data

Model							
Type		MAK10-1	MAK10-2	MAK10-3	MAK10-4	MAK10-1 PS1	MAK10-2 PS2
Part number		MAK10-1101-4-00-F	MAK10-2202-4-00-F	MAK10-3303-5-00-F	MAK10-4404-5-00-F	MAK10-1112-4-00-F	MAK10-2224-5-00-F
Number of gas paths		1	2	3	4	1	2
Number of condensate pumps		1	2	3	4	2	4
Number of pre-separators		0	0	0	0	1	2
Docking Station		-	-	yes	yes	-	yes
Material of gas paths							
Cooling transmission / storage		aluminium tube / copper rod					
Cooling surface		PTFE coating					
Housing / sealings		PVDF / FPM					
Operating data							
Gas flow $V_n^{1)}$ at 65°C dp	l/hr	1 x 125	2 x 125	3 x 125	4 x 125	1 x 150	2 x 150
Gas flow $V_n^{1)}$ at 55°C dp	l/hr	1 x 175	2 x 175	3 x 175	4 x 175	1 x 200	2 x 200
Gas inlet temperature	°C	max. 140					
Ambient temperature	°C	+5 to +45					
Operating pressure	bar	0,2 to 2,2					
Outlet dew point ¹⁾	°C	3,0 ± 0,3 at constant conditions					
Dead space per gas path	ml	26					
Ready for start up	min	< 5	< 10	< 15	< 15	< 5	< 10
Cooling capacity	KJ/hr	792					
Design data							
Dimensions (W x H x D)	mm	310 x 266 x 321		449 x 266 x 321		310 x 266 x 321	449 x 266 x 321
Weight without options	kg	16,0	18,0	20,8	23,0	17,0	20,0
Housing		wall mounting (19"- rack and mobile optional) / RAL 7035					
Connections		gas: PVDF DN 4/6 / condensate: PVDF DN 4/6					
Electrical data							
Mains connection		plug					
Digital display		temperature (outlet dew point resp. ambient), operating status, alarm and alarm storage, service control, operating hours, condensate pump control					
Alarm set-points	°C	< +2.0 / > +10.0					
Protection rate		IP 20 EN 60529 / EN 61010					
Conformity		CE /cMETus 					
Power supply		230V 50/60Hz or 115V 50/60Hz					
Power consumption	W	170 - 195		235 - 270		170 - 195	

¹⁾ at 25°C ambient temperature
dp = inlet dew point

Options	
<ul style="list-style-type: none"> ▪ Condensate pump ▪ PTFE or glass fiber depth filter, length 70mm or 90mm ▪ Sample gas pump N86 IP00 or IP20 ▪ Flow meter for max. 150 or 250 or 500 l/h ▪ Flow meter with light barrier and electronic ▪ Liquid sensor internal or external incl. electronic 	<ul style="list-style-type: none"> ▪ Pre-separator incl. condensate pump ▪ Acid dosing incl. condensate pump ▪ Docking Station ▪ 19"-rack ▪ Carrying handles ▪ Voltage 115V 50/60H
<p>Due to the large number of options a big variety of individual configurations of the MAK10 is possible. Basically, devices with 3-4 heat exchangers, 3-4 condensate pumps, 1-2 sample gas pumps, 2 filters and 2 flow meters need additionally always the docking station. Thereby the housing width changes from 310mm to 449mm. For your individual configuration of a MAK10 please contact our sales team in Steinbach.</p>	

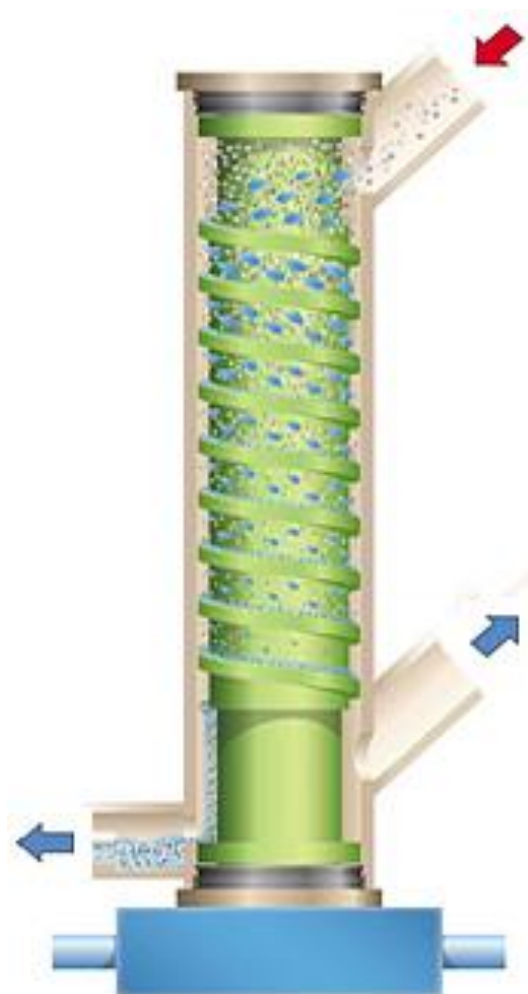
MAK 10 Compact Gas Conditioning-System

More efficiency, no energy losses, even at high and low temperatures

- ✓ Coldness transfer through copper and aluminum
- ✓ Best thermal conductance values 300/204 W/m²K
- ✓ Coldness transferred from the inside outwards
- ✓ Extremely compact design
- ✓ Optimal shielding from the environment

High and constant dryness rate even at extreme load changes

- ✓ PTFE-coated, hydrophobic surface
- ✓ Immediate formation of large condensate droplets
- ✓ Spiral performing stream goes downwards
- ✓ Consistent use of gravity
- ✓ Discharge of condensate at the lowest point
- ✓ Inner copper rod as cold storage

Exceptionally low gas dissolution rates enable accurate analysis

- ✓ Very low dead volume
- ✓ Extremely short retention time of the gas in the system
- ✓ Small heat-exchanger surface
- ✓ Rapid saturation of the surface
- ✓ Reduced response-time of gas to condensate
- ✓ Minimized contact surface of sample gas and condensate
- ✓ On three sides evacuated condensate spiral stream
- ✓ Coating reduces electrostatics

Reliability and sustainability reduce time and efforts maintenance

- ✓ Exchangeable heat-exchangers
- ✓ Optimum chemical resistance
- ✓ No abrasive wear-out
- ✓ Self-cleaning effects, no contamination
- ✓ Maintenance-free system
- ✓ Proven and safe technology
- ✓ Monitored quality
- ✓ More than 10.000 systems in successful operation

MAK 10 model example	
<p>MAK10-2</p> <ul style="list-style-type: none"> ✓ 2 heat exchangers PTFE / PVDF ✓ 2 gas paths (2 x 175 l/h) ✓ 2 condensate pumps ✓ 1 MAK-alarm contact 	
<p>MAK10-2 mobile version</p> <ul style="list-style-type: none"> ✓ 2 heat exchanger PTFE / PVDF ✓ 1 gas path (1 x 175 l/h) ✓ 2 condensate pumps ✓ 1 depth filter ✓ 1 liquid sensor and electronic ✓ 1 flow meter ✓ 1 MAK- / 1 sensor alarm contact 	
<p>MAK10-2 PS2</p> <ul style="list-style-type: none"> ✓ 2 heat exchangers PTFE / PVDF ✓ 2 gas paths (2 x 200 l/h) ✓ 2 pre-separators ✓ 4 condensate pumps ✓ 2 depth filters ✓ 2 liquid sensors and electronics ✓ 1 MAK- / 2 sensor alarm contacts 	
<p>MAK10-2 19"-rack version</p> <ul style="list-style-type: none"> ✓ 2 heat exchangers PTFE / PVDF ✓ 1 gas path (1 x 175 l/h) ✓ 2 condensate pumps ✓ 1 depth filter ✓ 1 liquid sensor and electronic ✓ 1 flow meter ✓ 1 MAK- / 1 sensor alarm contact 	

Configuration examples

MAK10-1

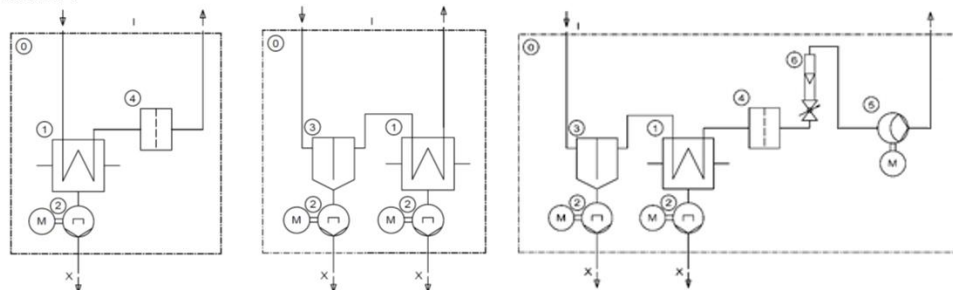

MAK10-2

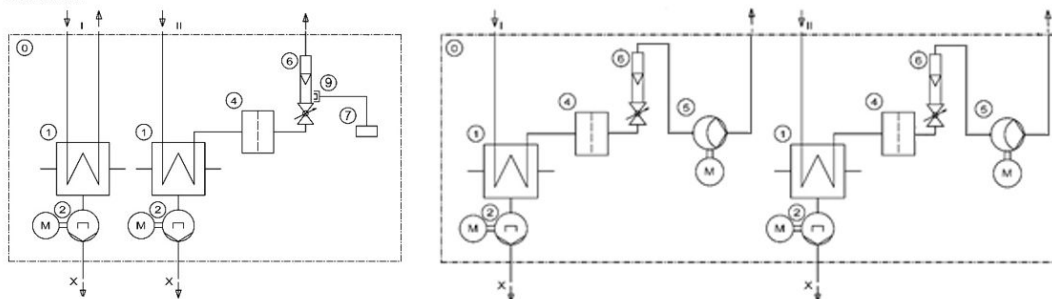

MAK10-3

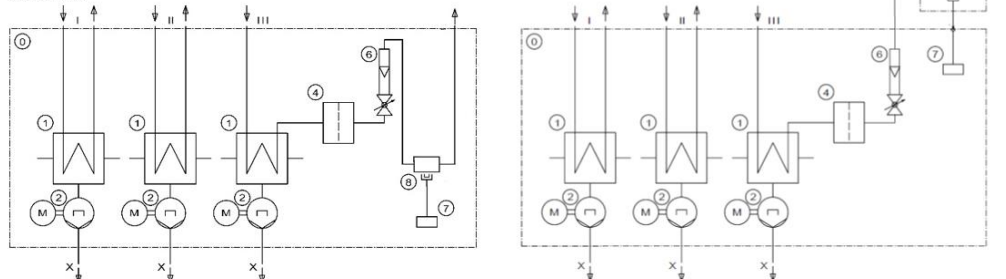

MAK10-4

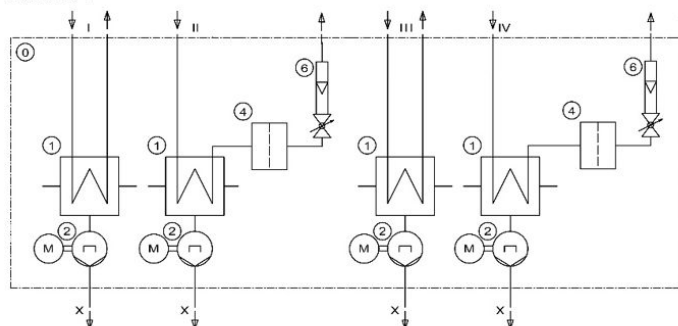

- ① Heat exchanger
- ② Condensate pump
- ③ Condensate pre-separator
- ④ Depth filter
- ⑤ Sample gas pump
- ⑥ Flow meter
- ⑦ Electronic
- ⑧ Liquid sensor
- ⑨ Light barrier

State 05 / 2021 | Subject to change

Integrated Components / Options
Condensate pump

- ✓ Reliable continuous condensate disposal
- ✓ Low speed, long-lasting pump hose

Condensate pre-separator

- ✓ Deposition of free condensate and solids
- ✓ Measuring gas pre-cooling for input dew points >65°C

Teflon Depth Filter

- ✓ Reliable solid particle filtration
- ✓ Easy and fast filter element change

Flow meter

- ✓ Optional with light barrier
- ✓ Precise dosing, with needle fine regulating valve

Liquid sensor

- ✓ Protects against condensate breakthrough
- ✓ Safe detection of even the smallest amounts of liquid

Electronics

- ✓ Control / Alarm for humidity sensors / light barrier
- ✓ Potential-free switching contact

Sample gas pump

- ✓ Unadulterated conveying of measuring gases
- ✓ Perfect integration into the cooler

